

CTLM3410-M832D
 CTLM7410-M832D
 CTLM3474-M832D

**SURFACE MOUNT
 DUAL, LOW $V_{CE(SAT)}$
 SILICON TRANSISTORS**

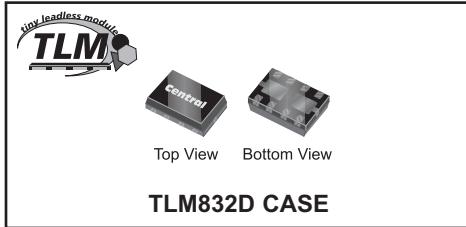

www.centrasemi.com

DESCRIPTION:

The CENTRAL SEMICONDUCTOR CTLM3410-M832D (Dual NPN), CTLM7410-M832D (Dual PNP), and CTLM3474-M832D (Complementary NPN & PNP) are Low $V_{CE(SAT)}$ Transistors packaged in the small, thermally efficient, 3x2mm Tiny Leadless Module (TLM™) surface mount case. These devices are designed for applications where small size, operational efficiency, and low energy consumption are the prime requirements. Due to its leadless package design this device is capable of dissipating up to 4 times the power of similar devices in comparable sized surface mount packages.

MARKING CODES:

CTLM3410-M832D: CFG

CTLM7410-M832D: CFH

CTLM3474-M832D: CFJ

APPLICATIONS

- Switching Circuits
- DC - DC Converters
- LCD Backlighting
- Battery powered / Portable Equipment applications including Cell Phones, Digital Cameras, Pagers, PDAs, Notebook PCs, etc.

MAXIMUM RATINGS: ($T_A=25^{\circ}C$)

Collector-Base Voltage
 Collector-Emitter Voltage
 Emitter-Base Voltage
 Continuous Collector Current
 Power Dissipation (Note 1)
 Operating and Storage Junction Temperature
 Thermal Resistance

FEATURES

- Dual Chip Device
- High Current (1.0A) Transistors
- Low $V_{CE(SAT)}$ Transistors (450mV @ $I_C=1.0A$ MAX)
- High Power to Footprint Ratio of 275mW per sq mm (Package Power Dissipation / Package Surface Area)
- Small TLM 3x2mm Leadless Surface Mount Package
- Complementary Devices

SYMBOL		UNITS
V_{CBO}	40	V
V_{CEO}	25	V
V_{EBO}	6.0	V
I_C	1.0	A
P_D	1.65	W
T_J, T_{stg}	-65 to +150	$^{\circ}C$
θ_{JA}	76	$^{\circ}C/W$

ELECTRICAL CHARACTERISTICS PER TRANSISTOR: ($T_A=25^{\circ}C$ unless otherwise noted)

SYMBOL	TEST CONDITIONS	MIN	NPN		PNP		UNITS
				TYP	TYP	MAX	
I_{CBO}	$V_{CB}=40V$				100	nA	
I_{EBO}	$V_{EB}=6.0V$				100	nA	
BV_{CBO}	$I_C=100\mu A$	40				V	
BV_{CEO}	$I_C=10mA$	25				V	
BV_{EBO}	$I_E=100\mu A$	6.0				V	
$V_{CE(SAT)}$	$I_C=50mA, I_B=5.0mA$		25	30	50	mV	
$V_{CE(SAT)}$	$I_C=100mA, I_B=10mA$		40	50	75	mV	

Notes: (1) FR-4 Epoxy PCB with copper mounting pad area of 54mm².

R3 (1-August 2011)

CTLM3410-M832D
 CTLM7410-M832D
 CTLM3474-M832D

**SURFACE MOUNT
 DUAL, LOW $V_{CE(SAT)}$
 SILICON TRANSISTORS**



ELECTRICAL CHARACTERISTICS PER TRANSISTOR - Continued: ($T_A=25^\circ\text{C}$)

SYMBOL	TEST CONDITIONS	MIN	NPN		PNP		UNITS
			TYP	TYP	MAX	TYP	
$V_{CE(SAT)}$	$I_C=200\text{mA}$, $I_B=20\text{mA}$		80	95	150		mV
$V_{CE(SAT)}$	$I_C=500\text{mA}$, $I_B=50\text{mA}$		190	205	250		mV
$V_{CE(SAT)}$	$I_C=800\text{mA}$, $I_B=80\text{mA}$		290	320	400		mV
$V_{CE(SAT)}$	$I_C=1.0\text{A}$, $I_B=100\text{mA}$		360	400	450		mV
$V_{BE(SAT)}$	$I_C=800\text{mA}$, $I_B=80\text{mA}$				1.1		V
$V_{BE(ON)}$	$V_{CE}=1.0\text{V}$, $I_C=10\text{mA}$				0.9		V
h_{FE}	$V_{CE}=1.0\text{V}$, $I_C=10\text{mA}$	100					
h_{FE}	$V_{CE}=1.0\text{V}$, $I_C=100\text{mA}$	100			300		
h_{FE}	$V_{CE}=1.0\text{V}$, $I_C=500\text{mA}$	100					
h_{FE}	$V_{CE}=1.0\text{V}$, $I_C=1.0\text{A}$	50					
f_T	$V_{CE}=10\text{V}$, $I_C=50\text{mA}$, $f=100\text{MHz}$	100					MHz
C_{ob}	$V_{CB}=10\text{V}$, $I_E=0$, $f=1.0\text{MHz}$ (CTLM3410-M832D)		6.0		10		pF
C_{ob}	$V_{CB}=10\text{V}$, $I_E=0$, $f=1.0\text{MHz}$ (CTLM7410-M832D)			10	15		pF

TLM832D CASE - MECHANICAL OUTLINE

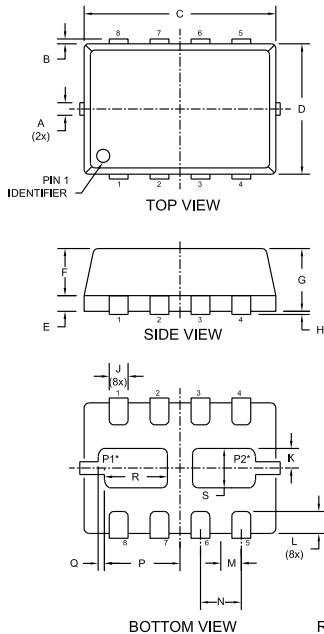

SYMBOL	DIMENSIONS			
	INCHES		MILLIMETERS	
	MIN	MAX	MIN	MAX
A	0.007	0.012	0.170	0.300
B	-	0.005	-	0.125
C	0.114	0.122	2.900	3.100
D	0.075	0.083	1.900	2.100
E	0.006	0.010	0.150	0.250
F	0.026	0.030	0.650	0.750
G	0.031	0.039	0.800	1.000
H	0.000	0.002	0.000	0.050
J	0.009	0.013	0.240	0.340
K	0.006	0.014	0.160	0.360
L	0.008	0.018	0.200	0.450
M	0.013		0.325	
N	0.026		0.650	
P	0.040	0.048	1.010	1.210
Q	0.004		0.100	
R	0.032	0.040	0.820	1.020
S	0.017	0.025	0.430	0.630

TLM832D (REV: R2)

LEAD CODES:

- 1) Base Q1 5) Collector Q2
- 2) Emitter Q1 6) Collector Q2
- 3) Base Q2 7) Collector Q1
- 4) Emitter Q2 8) Collector Q1

* Note:
 - Exposed pad P1 common to pins 7 and 8
 - Exposed pad P2 common to pins 5 and 6

**CTLM3410-M832D
 Dual NPN
 Marking Code: CFG**

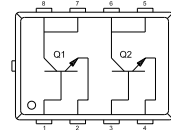

**CTLM7410-M832D
 Dual PNP
 Marking Code: CFH**

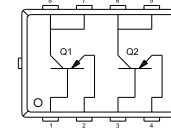

**CTLM3474-M832D
 Complementary NPN & PNP
 Marking Code: CFJ**

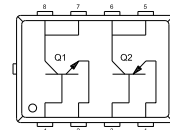

R3 (1-August 2011)