

CEDM8004

**SURFACE MOUNT
P-CHANNEL
ENHANCEMENT-MODE
SILICON MOSFET**



www.centrasemi.com

TLP Tiny Leadless Package

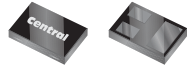

Top View Bottom View

SOT-883L CASE

• Devices are **Halogen Free** by design

APPLICATIONS:

- Load/Power Switches
- Power Supply Converter Circuits
- Battery Powered Portable Devices

MAXIMUM RATING: (T_A=25°C)

Drain-Source Voltage
 Gate-Source Voltage
 Continuous Drain Current
 Power Dissipation
 Operating and Storage Junction Temperature

SYMBOL

V_{DS} 30
 V_{GS} 8.0
 I_D 450
 P_D 100
 T_J, T_{stg} -65 to +150

UNITS

V
 V
 mA
 mW
 °C

ELECTRICAL CHARACTERISTICS: (T_A=25°C unless otherwise noted)

SYMBOL	TEST CONDITIONS	MIN	TYP	MAX	UNITS
I _{GSSF} , I _{GSSR}	V _{GS} =8.0V, V _{DS} =0			3.0	μA
I _{DSS}	V _{DS} =30V, V _{GS} =0			1.0	μA
BV _{DSS}	V _{GS} =0, I _D =100μA	30			V
V _{GS(th)}	V _{DS} =V _{GS} , I _D =250μA	0.5		1.0	V
V _{SD}	V _{GS} =0, I _S =100mA			1.1	V
r _{DS(ON)}	V _{GS} =4.5V, I _D =430mA			1.1	Ω
r _{DS(ON)}	V _{GS} =2.5V, I _D =200mA			2.0	Ω
r _{DS(ON)}	V _{GS} =1.8V, I _D =100mA			3.3	Ω
Q _{g(tot)}	V _{DS} =10V, V _{GS} =4.5V, I _D =1.0A		0.88		nC
Q _{gs}	V _{DS} =10V, V _{GS} =4.5V, I _D =1.0A		0.35		nC
Q _{gd}	V _{DS} =10V, V _{GS} =4.5V, I _D =1.0A		0.128		nC
g _{FS}	V _{DS} =10V, I _D =100mA	200			mS
C _{rss}	V _{DS} =25V, V _{GS} =0, f=1.0MHz			10	pF
C _{iSS}	V _{DS} =25V, V _{GS} =0, f=1.0MHz			55	pF
C _{OSS}	V _{DS} =25V, V _{GS} =0, f=1.0MHz			15	pF

R3 (2-August 2011)

CEDM8004
SURFACE MOUNT
P-CHANNEL
ENHANCEMENT-MODE
SILICON MOSFET



SOT-883L CASE - MECHANICAL OUTLINE

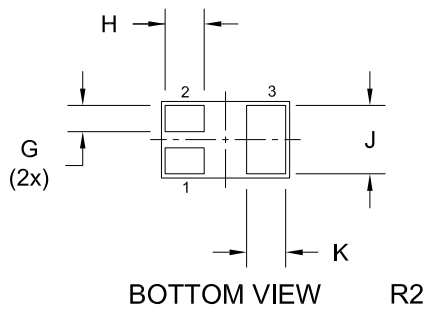
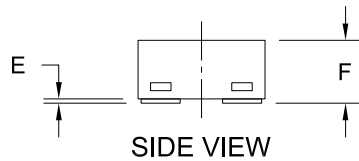
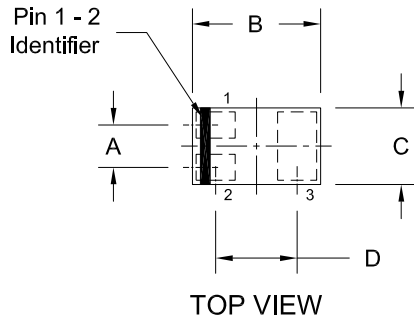

DIMENSIONS				
SYMBOL	INCHES		MILLIMETERS	
	MIN	MAX	MIN	MAX
A	0.014		0.35	
B	0.037	0.041	0.95	1.05
C	0.022	0.026	0.55	0.65
D	0.026		0.65	
E	0.000	0.002	0.00	0.05
F	0.012	0.016	0.30	0.40
G	0.005	0.007	0.13	0.18
H	0.008	0.012	0.20	0.30
J	0.018	0.022	0.45	0.55
K	0.008	0.012	0.20	0.30

SOT-883L (REV:R2)

PIN CONFIGURATION
(Bottom View)

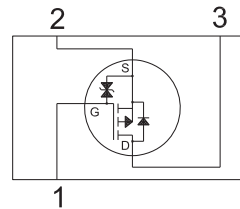

LEAD CODE:

- 1) Gate
- 2) Source
- 3) Drain

MARKING CODE: V

R3 (2-August 2011)