

# Package Details

## SOT-223 Case

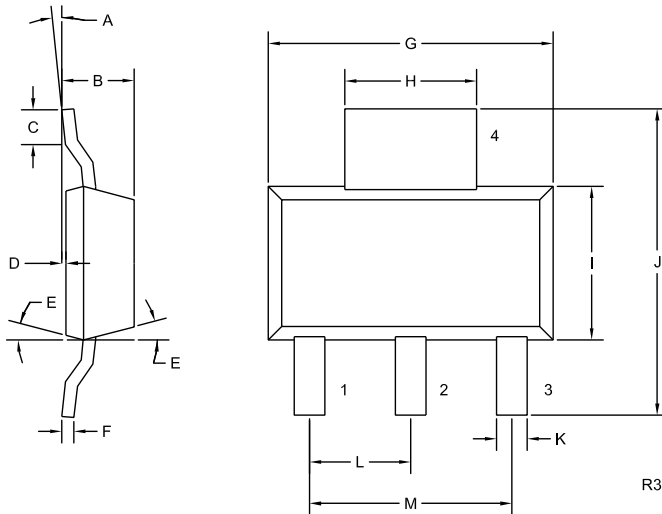

### Mechanical Drawing



SYMBOL	INCHES		MILLIMETERS	
	MIN	MAX	MIN	MAX
A	0°	10°	0°	10°
B	0.059	0.071	1.50	1.80
C	0.018	—	0.45	—
D	0.000	0.004	0.00	0.10
E	15°		15°	
F	0.009	0.014	0.23	0.35
G	0.248	0.264	6.30	6.70
H	0.114	0.122	2.90	3.10
I	0.130	0.146	3.30	3.70
J	0.264	0.287	6.70	7.30
K	0.024	0.033	0.60	0.85
L	0.091		2.30	
M	0.181		4.60	

SOT-223 (REV: R3)

**Lead Code:**  
Reference individual device datasheet.

**Part Marking:** Full Part Number

### Mounting Pad Geometry (Dimensions in mm)

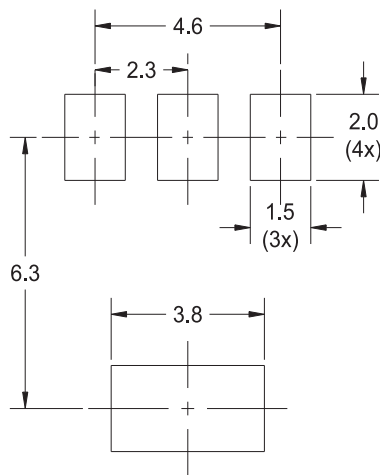

R1

R4 (4-March 2010)

# Package Details

## SOT-223 Case



### Tape Dimensions and Orientation (Dimensions in mm)

Tape Width: 12mm

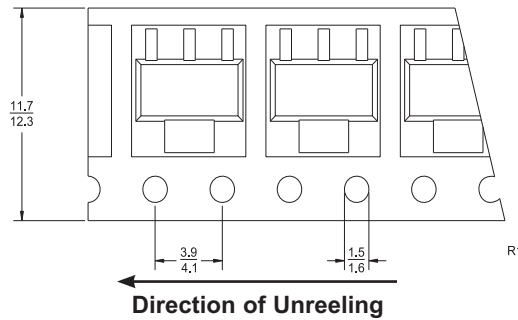

Devices are taped in accordance with Electronic Industries Association Standard EIA-481-1-A

### Packaging Base

7" Reel = 1,000 pcs.  
13" Reel = 4,000 pcs.

### Reel Labeling Information

**Each reel is labeled with the following information:**

Central Part Number, Customer Part Number, Purchase Order Number, Quantity, Lot Number, Date Code and Ship Date.

### Reel Packing Information

Reel Size	Reels per Box (Maximum)	Parts per Box (Maximum)	Box Dimensions		Shipping Weight (Max.)	
			INCH	CM	LB	KG
7"	6	6,000	9x9x5	23x23x13	4	2
	13	13,000	9x9x9	23x23x23	7	4
	32	32,000	21x9x9	53x23x23	16	8
	82	82,000	27x9x17	69x23x43	43	20
13"	5	20,000	15x4x15	38x10x38	10	5
	14	56,000	15x15x9	38x38x23	29	14
	26	104,000	15x15x18	38x38x46	53	24

### Ordering Information

- For devices taped and reeled on 7" reels, add TR suffix to part number.
- For devices taped and reeled on 13" reels, add TR13 suffix to part number.
- All SMDs are available in small quantities for prototype and manual placement applications.

R4 (4-March 2010)